

US Navy

RTI selected for HiPer-D and Navy Open Architecture

“The RTI Data Distribution Service COTS publish/subscribe middleware was chosen for the missile guidance communications interface between SPY Radar Control Computer Program (RCCP) and Weapon Control System (WCS). Over this communications interface the SM2 missile guidance uplink and downlink commands are transmitted. SPY receives the downlink from the SM2 missile, and transmits the data to WCS. WCS processes the data, basically determining steering commands for the missile, and returns an uplink data message to SPY. SPY sends the steering commands to the missile. This uplink/ downlink process continues until the missile hits the target. Using RTI, the communications link performance was better than that measured in the fleet system.”

Advanced Computing Test Bed
Demonstration 2000

Report dated December 31, 2000.

The Naval Sea Systems Command (NAVSEA) Dahlgren Division was tasked with investigating how to apply advanced technologies and concepts to the Naval Surface Ship Anti-Air Warfare (AAW) problem domain. The project was ordered by the Aegis Program Office (NAVSEA PMS 400) under the High Performance Distributed Computing Project (HiPer-D), and the Defense Advanced Research Projects Agency (DARPA)-sponsored Quorum Project.

The first phase of the program, funded primarily by DARPA, involved developing a prototype of selected DARPA technologies, and then evaluating and demonstrating that prototype.

The second phase, funded primarily by PMS 400, involved expanding and enhancing the prototype, as well as incorporating COTS and DARPA technologies. This phase focused on reducing risks that were identified by Aegis as critical technology and system issues.

HiPer-D commenced in June 1991 with an overall goal of conducting critical experiments to assist Aegis in making the transition from a centralized, standard Navy computer architecture to a commercially based distributed architecture. The two principal engineering organizations performing the work in HiPer-D were the Naval Surface Warfare Center at Dahlgren, Virginia and the Johns Hopkins University Applied Physics Laboratory at Laurel, Maryland.

The HiPer-D Project Goals

Today's tactical systems often exhibit degraded performance as the load increases. The HiPer-D goal was to define a new computer program and system architecture that fully exploited COTS technology. This allowed the team to investigate technologies that support real-time, distributed, scalable, fault tolerant, heterogeneous computing systems. The intended use of this newly architected combat system was the Aegis

Baseline 7 combat system. To support Aegis Baseline 7 development, HiPer-D needed to provide solutions for the following technical challenges:

- Fault tolerance via replication
- Rapid upgrade
- Technology insertion and refresh
- Operational flexibility via dynamic resource allocation
- Load-invariant computing performance via scalability and distributed processing
- New tactical capability insertion via open system designs
- Reduced life-cycle cost through use of the latest computing technologies

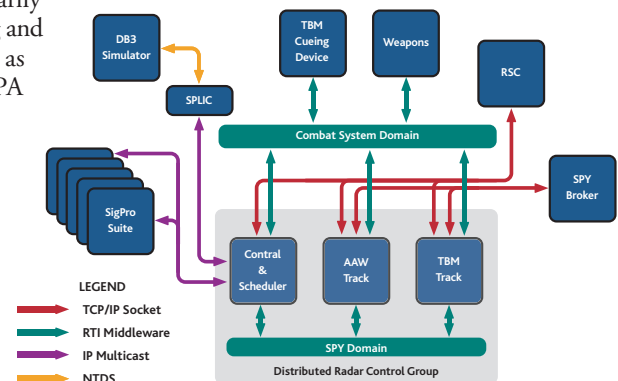

HiPer-D Test Bed Demos

There have been several HiPer-D Test Bed Demos over the past eight years. The first formal T1 test bed (May 15, 1995) yielded unprecedented results. The goal of this Phase 2 effort was to prove that COTS technology could support the engineering development of large scale, complex, distributed-based systems. Each successive demo produced significant findings, and DARPA and the Aegis Program Office continued to fund the HiPer-D effort. One of the technical objectives of the 1998 demo was to evolve toward long-term use of middleware. This involved the integration of RTI Data Distribution Service (formerly NDDS) and CORBA® middleware products.



Why RTI's COTS solution was chosen

RTI was chosen as the COTS data-centric middleware because it provided:

- Efficient distribution of continuously-refreshed data
- High data-rate communications
- Location transparency
- Load balancing, share track data processing over many CPUs for load-invariant performance (10k+ tracks!)
- Simplified design
- One-to-many or many-to-many communications

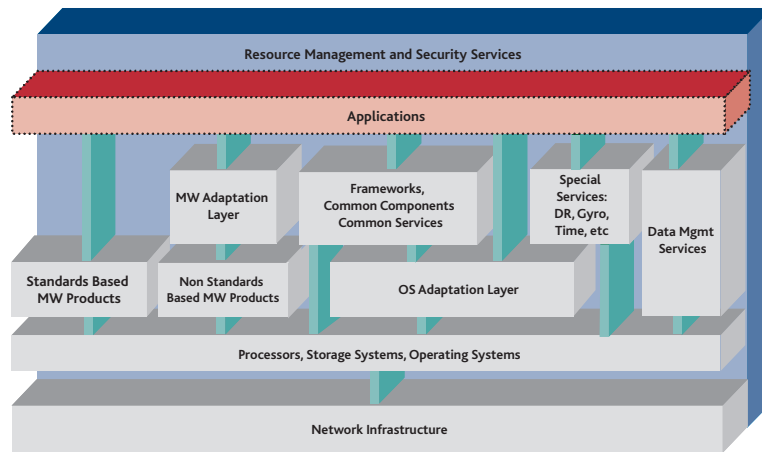

Navy Open Architecture & HiPer-D Project

The Navy Open Architecture (NOA) design guidance is an outgrowth of a decade of shared technology and architecture evaluation and risk mitigation by the Navy, the Defense Advanced Research Projects Agency (DARPA), academia and industry. The HiPer-D Program performed system-scale prototyping directed toward these new open architectural principles. The Open Architecture goals can be articulated as follows:

- Reduce total ownership cost
- Make system change and upgrade easier and faster
- Lower the impact of commercial off-the shelf (COTS) computing technology refreshes
- Reduce compatibility and interoperability problems

The NOA initiative will accomplish these goals by evolving Navy surface ship warfighting systems from the current status quo (many warfighting systems and ship classes developed over time and under less than fully coordinated acquisition strategies), toward a unified Navy warfighting system product line.

Conclusion

The HiPer-D Advance Computing Test Bed successfully demonstrated that available COTS technology is capable of supporting the design and implementation of complex high-performance weapon systems. RTI was employed to provide the real-time data-centric publish-subscribe COTS middleware that was essential in meeting the time-critical performance demands of load-invariant system behavior. Furthermore, with COTS-based middleware solutions, the HiPer-D team successfully created a prototype system that:

- Delivered load-invariant performance
- Provided high-availability
- Detected, controlled, engaged, and tracked thousands of targets
- Coordinated hundreds of computers on multiple ships

The OA Design Guidance has built upon the success of HiPer-D and will directly impact how future weapon systems are architected. Now that the Object Management Group (OMG) has ratified the Data Distribution Service (DDS) Specification, the OA program has embraced the OMG standard.

About RTI

RTI supplies middleware and distributed data management solutions for real-time systems. With innovative technology and deep expertise in distributed applications, RTI provides an unequalled competitive advantage to customers developing systems that benefit from high-performance access to time-critical data. RTI solutions have been deployed in a broad range of applications including command and control, intelligence, surveillance, data fusion, simulation, industrial control, air traffic control, railway management, roadway traffic monitoring and multimedia communications. Founded in 1991, RTI is privately held and headquartered in Santa Clara, California.